

type SPI-1 32  
SPI-2 32

03/2022



**⚠** Above stated body materials refer to the valve port connections that get in contact with the media only!

**details needed for main valve**

- orifice
- port
- pressure regulating range
- flow rate
- media
- media temperature
- ambient temperature

**details needed for proportional valve**

- nominal voltage
- actuation pressure range min/max
- setpoint signal

**⚠** The valves' technical design is based on media and application requirements. This can lead to deviations from the general specifications shown on the data sheet with regards to the design, sealing materials and characteristics.

**⚠** If order or application specifications are incomplete or imprecise there exists a risk of an incorrect technical design of the valve for the required application. As a consequence, the physical and / or chemical properties of the materials or seals used, may not be suitable for the intended application. To avoid hydraulic shocks in pipelines, the flow velocities must be taken into account when designing valves for liquids.

<b>control valve</b>	proportional	<b>externally controlled</b>
<b>pressure range</b>		PN 0-100 bar
<b>orifice</b>		DN 32 mm
<b>connection</b>		thread
<b>function</b>		stepless pressure regulation

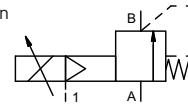

<b>operating principle</b>	externally controlled with spring return	
<b>body material</b>	① brass	④
	②	⑤
	③	⑥

<b>valve seat</b>	metal on metal	
<b>seal materials</b>	PU, NBR	FPM

	general specifications	options
<b>ports</b>	SPI-1 threads G 1 1/2 SPI-2 threads G 1 1/2	
<b>function</b>	stepless pressure regulation	
<b>pressure regulation range</b>	SPI-1 5-40	SPI-2 5-100
<b>flow rate</b>	m³/h max. 24,3	
<b>media</b>	gaseous - liquid - highly viscous - contaminated	
<b>abrasive media</b>		
<b>flow direction</b>	A ⇒ B as marked	
<b>settling time</b>	ms SPI-1 < 200	SPI-2 < 400
<b>media temperature</b>	°C 0 to +60	
<b>ambient temperature</b>	°C 0 to +50	
<b>approvals</b>		
<b>mounting</b>	mounting brackets	
<b>weight</b>	kg SPI-1 15,2	SPI-2 16,3
<b>additional equipment</b>		

	electrical specifications	options
<b>nominal voltage</b>	U <sub>B</sub> DC 24 V (max. residual ripple 10 %)	
<b>current consumption</b>	DC < 0,7 A	
<b>control signals</b>	U <sub>E</sub> 0-10 V (RE 100 KΩ)	4-20 mA (RE 250 KΩ)
<b>protection</b>	IP65 (P54) acc. DIN 40050	
<b>energized duty rating</b>	ED 100 % (observe the connection conditions accordingly)	
<b>connection</b>	plug with 7 contacts / wire diameter 6-8 mm	

	pneumatic specifications	options
<b>actuation pressure range</b>	bar see actuation pressure-diagram	
<b>compressed air</b>	DIN ISO 8573-1 grade of compressed air quality 5/4/3	
<b>control</b>	via 3/2 way proportional valve	
<b>actuator ports</b>	1 G 1/8	

**connection plan /**

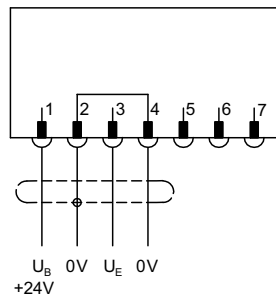

**connection conditions**

When supplying the electrical set point signal to the proportional valve, the actuating air must already be present. (see actuation pressure-diagram).

**position of installation**

arbitrary, but regulator not downwards.

■ specifications not highlighted are standard  
■ specifications highlighted in grey are optional

# coax® data sheet - pressure reduction valve

type SPI-1 32

SPI-2 32

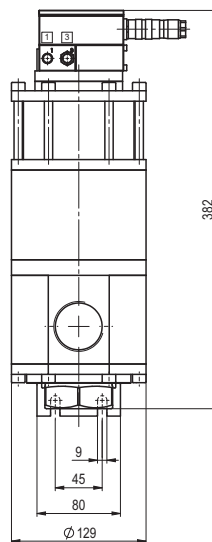
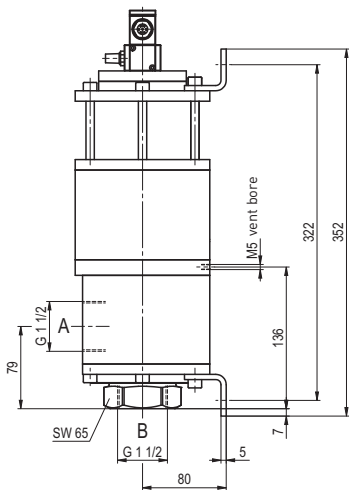
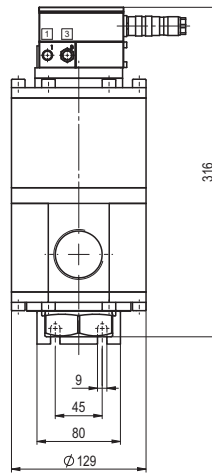
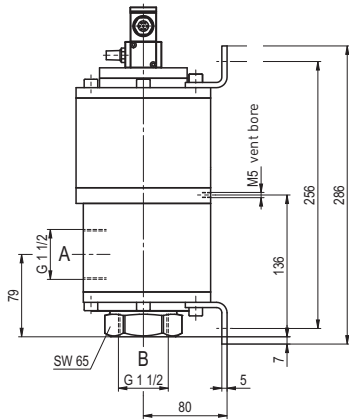

## actuation pressure-diagram

